

Air-Jets

Description

For supply air, high capacity air jet diffuser consisting of concentric rings assembled with a pivoting eyeball adjustment facility to 30° from its axis. Suitable for wall or duct mounting, especially high installation applications.

Construction

From spun 1.6mm thick aluminium rings set in a 1.6mm thick aluminium flanged frame. Plenum connections from 1.0mm thick galvanised sheet steel. Optional OBD is of extruded aluminium.

Size and Weight

Each diffuser is available in 200, 250, 300 and 350 diameters and from 1 to a maximum of 4 units in width. Air jet approximately 15kg/m².

How to Specify

STATE QUANTITY, THE PRODUCT CODING AND THE SIZE WIDTH X HEIGHT

e.g. 10 Qty. J2CSV+1C 771 X 391.



Frame Style	Size Code	Options	Accessories
J1 One Element	A Ø 200	0 None	0 None
J2 Two Element	B Ø 250	P Square Duct Plenum	V Damper
J3 Three Element	C Ø 300	S Spiral Duct Plenum	
J4 Four Element	D Ø 350		

Fixings	Finish
1 Flange Holes	C PPC BS /RAL Colour
2 Neck Fixings	G RAL 9006 Satalum as Standard

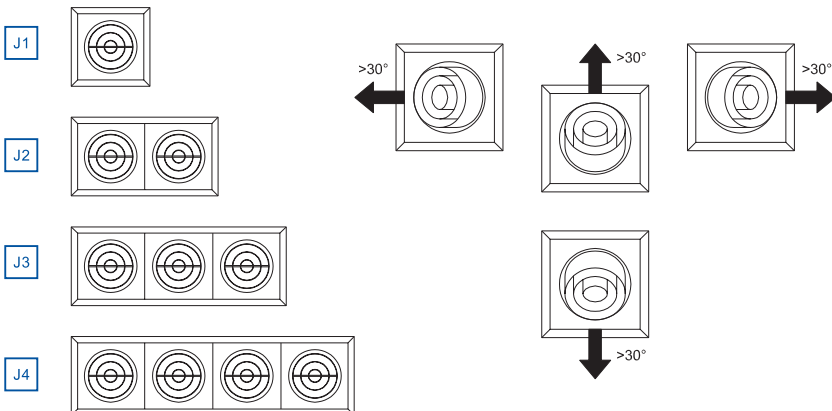

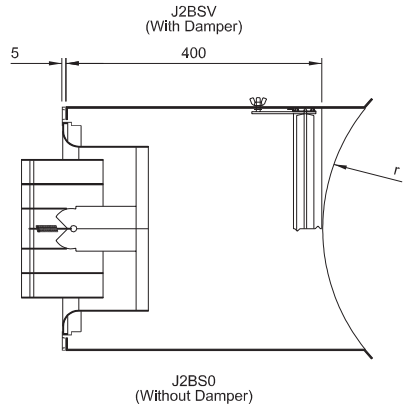
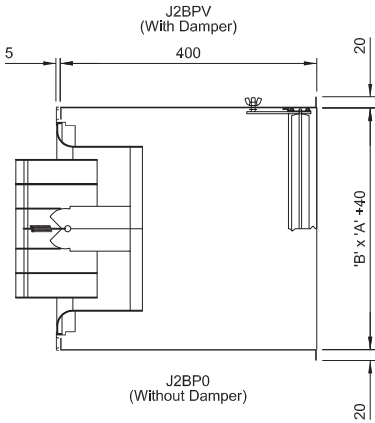
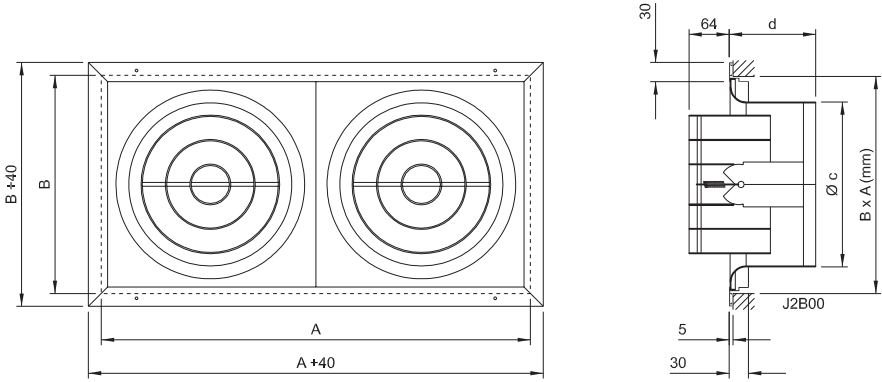





Ø 200	Dimensions (mm)			
	J1A	J2A	J3A	J4A
A	289	567	845	1123
B	289	289	289	289
c	206	206	206	206
d	120	120	120	120

A = Ø 200



Ø 300	Dimensions (mm)			
	J1C	J2C	J3C	J4C
A	391	771	1151	1531
B	391	391	391	391
c	308	308	308	308
d	146	146	146	146

C = Ø 300



Ø 250	Dimensions (mm)			
	J1B	J2B	J3B	J4B
A	340	669	998	1327
B	340	340	340	340
c	257	257	257	257
d	133	133	133	133

B = Ø 250



Ø 350	Dimensions (mm)			
	J1D	J2D	J3D	J4D
A	442	873	1304	1735
B	442	442	442	442
c	359	359	359	359
d	159	159	159	159

D = Ø 350

Technical Data Air-Jets

General

Data is based upon supply air being discharged into free space with no adjacent structural surfaces. Contact surfaces within approximately 20% of the throw distance will assist air flow and will subsequently increase the throw by up to 33%.

Nomenclature

q (l/s) = Air Volume; litres per second
 Lt (m) = Throw distance in metres to a given Vt
 Vt = Terminal velocity; metres per second
 Ps (Pa) = Static pressure drop (Pascals)
 NC = Noise criteria levels

Fig. 1. Performance Table

Throw values (Lt) are given for the **vertical** projection of **warm** air in metres from the outlet source to floor level where the terminal velocity (Vt) is taken to be zero. Data is based upon warm air 10°C above the average room temperature. Pressure drop and noise criteria (NC) are as per the corresponding air volumes and unit sizes given in the main performance table (Fig. 2.)

Fig. 2. Performance Table

Throw (Lt) is the horizontal distance in metres from the supply air source to that point at which the discharge velocity has been reduced to 0.25 M/s (Vt). Data is based on cooled air 10°C below the average room temperature and the adjustable air-jets set at 0° deflection.

Noise criteria

'NC' values are based on an 8dB deduction for average room absorption and sound power level (Lw) 10⁻². 'NC' values given in the tables are based on measurement at 1.5 metres from the supply air source. In large free spaces it may be desirable to consider the likely reduction in sound at greater distances.

5 METRES -5NC 7.5 METRES -7NC 10 METRES -12NC

Fig. 1. VERTICAL downward projection of warm air (Throw distance in metres)

q(l/s)	A Ø 200				B Ø 250				C Ø 300				D Ø 350			
	J1 (J5)	J2	J3	J4	J1 (J5)	J2	J3	J4	J1 (J5)	J2	J3	J4	J1 (J5)	J2	J3	J4
150	5	3														
200	7	4			6											
250	8	5			7	4										
300	10	6	5		8	5	4		6							
400		8	7	5	12	7	5	3	9	5						
500		13	8	6	14	8	6	5	11	7			10			
600		15	9	8		11	7	6	14	8			11	6		
700		16	11	10		14	8	7	16	10	6		12	7		
800			13	12		16	10	8		12	7	6	14	8		
900			14	13			12	10		14	8	7	15	9	6	
1000				15			15	12		15	9	8		11	8	
1200				18				15			11	9		13	10	8
1400								17			13	11			12	9
1600												13			14	10
1800												15			16	12
2000												17				14
2200																15

Terminal velocity (Vt)

Throw values in Fig. 2. are based on 0.25 M/s Vt. For a 0.5 M/s Vt a factor of **x 0.65** should be applied. Terminal velocity for the vertical projection of warm air is taken as zero Vt.

Air-jet adjustment

To counteract rise or drop of the air stream the individual air-jet elements can be adjusted up or down 30°. Such adjustment of a single air-jet element in a multi-element panel (J2, J3 or J4) will reduce the throw to approximately the equivalent throw distance of a single element unit (J1) supplying an equally proportionate air volume. The effect on pressure drop and 'NC' will be as follows:

ADJUSTMENT TO 15° Ps x 1.2 +3NC

ADJUSTMENT TO 30° Ps x 1.35 +4NC

Volume control





The optional rear opposed blade volume control damper (type 'V') is externally operated via a lockable hand lever device and is intended for 'trimming' the air volume. Harsh adjustment should be avoided as this will adversely increase pressure drop and noise. For guidance the closure of the damper by 25% will add +15Pa and +5NC. For potential pressure drops in excess of 150 Pascals a more substantial type of volume controller should be chosen.

Optional 'J5' series

An optional single element unit with a circular front face is available (J5). To select sizes refer to data in the tables under 'J1 (J5)'

Technical Data Air-Jets

Fig. 2. HORIZONTAL projection of cool air (Lt = Throw distance in metres)

q (l/s)	Ø (mm)	J1 			J5 			J2 			J3 			J4 		
		Lt (m)	Ps (Pa)	NC	Lt (m)	Ps (Pa)	NC	Lt (m)	Ps (Pa)	NC	Lt (m)	Ps (Pa)	NC	Lt (m)	Ps (Pa)	NC
100	A (200)	7	20	18	-	-	-	-	-	-	-	-	-	-	-	
150	A (200)	9	32	23	-	-	-	-	-	-	-	-	-	-	-	
200	A (200)	13	53	28	-	-	-	-	-	-	-	-	-	-	-	
	B (250)	10	22	-	-	-	-	-	-	-	-	-	-	-	-	
250	A (200)	15	87	32	9	24	21	-	-	-	-	-	-	-	-	
	B (250)	12	32	25	8	14	-	-	-	-	-	-	-	-	-	
300	A (200)	18	135	37	12	32	24	9	20	19	-	-	-	-	-	
	B (250)	15	40	28	9	18	18	7	12	-	-	-	-	-	-	
	C (300)	13	21	20	6	9	-	-	-	-	-	-	-	-	-	
400	A (200)	-	-	-	15	56	28	12	30	22	8	17	20	-	-	
	B (250)	20	75	34	12	25	23	9	17	-	6	8	-	-	-	
	C (300)	16	33	25	10	12	18	-	-	-	-	-	-	-	-	
500	A (200)	-	-	-	20	115	36	14	44	26	11	29	23	-	-	
	B (250)	26	123	44	15	40	25	11	19	21	9	14	19	-	-	
	C (300)	21	52	32	14	18	22	-	-	-	-	-	-	-	-	
	D (350)	18	27	23	10	10	-	-	-	-	-	-	-	-	-	-
600	A (200)	-	-	-	23	150	42	15	68	32	13	42	27	-	-	
	B (250)	29	195	49	18	49	30	12	25	24	10	16	20	-	-	
	C (300)	26	66	38	16	26	26	-	-	-	7	8	-	-	-	
	D (350)	20	39	28	11	14	18	-	-	-	-	-	-	-	-	-
700	A (200)	-	-	-	25	180	48	17	83	37	15	53	31	-	-	
	B (250)	-	-	-	21	70	34	14	32	27	12	20	22	-	-	
	C (300)	29	88	43	19	35	31	11	12	18	8	10	-	-	-	
	D (350)	24	53	33	13	18	19	-	-	-	-	-	-	-	-	-
800	A (200)	-	-	-	-	-	-	20	115	41	18	70	34	-	-	
	B (250)	-	-	-	25	90	40	16	40	32	14	30	24	-	-	
	C (300)	32	118	48	22	42	34	12	19	20	12	15	19	-	-	
	D (350)	27	76	40	17	24	24	10	10	-	-	-	-	-	-	-
900	A (200)	-	-	-	-	-	-	22	135	44	20	88	37	-	-	
	B (250)	-	-	-	28	125	43	19	51	37	16	42	26	-	-	
	C (300)	-	-	-	25	59	37	14	24	22	13	18	21	-	-	
	D (350)	30	108	43	19	35	29	11	14	-	-	-	-	-	-	-
1000	A (200)	-	-	-	-	-	-	24	185	48	23	106	40	-	-	
	B (250)	-	-	-	30	160	49	22	63	40	18	49	29	-	-	
	C (300)	-	-	-	27	75	41	17	32	25	14	22	22	-	-	
	D (350)	40	190	50	21	43	31	13	18	19	10	9	-	-	-	-
1200	A (200)	-	-	-	-	-	-	-	-	-	26	173	46	-	-	
	B (250)	-	-	-	-	-	-	25	78	43	21	59	32	-	-	
	C (300)	-	-	-	31	93	45	20	43	31	17	28	26	-	-	
	D (350)	-	-	-	27	52	34	17	24	22	14	12	18	-	-	-
1400	A (200)	-	-	-	-	-	-	-	-	-	28	210	51	-	-	
	B (250)	-	-	-	-	-	-	29	99	48	23	72	35	-	-	
	C (300)	-	-	-	34	118	50	23	54	35	18	35	29	-	-	
	D (350)	-	-	-	31	70	37	21	35	26	16	17	23	-	-	-
1600	B (250)	-	-	-	-	-	-	-	-	-	25	81	37	-	-	
	C (300)	-	-	-	38	140	54	27	69	38	21	40	33	-	-	
	D (350)	-	-	-	35	86	42	23	48	30	18	26	28	-	-	-
	B (250)	-	-	-	-	-	-	-	-	-	28	118	42	-	-	
1800	C (300)	-	-	-	-	-	-	30	83	43	23	49	36	-	-	
	D (350)	-	-	-	38	120	46	26	59	35	20	38	31	-	-	-
	B (250)	-	-	-	-	-	-	-	-	-	30	138	45	-	-	
	C (300)	-	-	-	-	-	-	34	108	47	26	59	40	-	-	
2000	D (350)	-	-	-	42	155	52	30	75	39	23	50	35	-	-	
	B (250)	-	-	-	-	-	-	-	-	-	33	176	50	-	-	
	C (300)	-	-	-	-	-	-	38	140	52	29	72	43	-	-	
	D (350)	-	-	-	45	190	56	34	93	43	25	62	38	-	-	-
2400	B (250)	-	-	-	-	-	-	-	-	-	-	-	-	-	-	
	C (300)	-	-	-	-	-	-	-	-	-	33	88	47	-	-	
	D (350)	-	-	-	-	-	-	37	125	46	27	76	41	-	-	-
	C (300)	-	-	-	-	-	-	-	-	-	36	105	49	-	-	
2600	D (350)	-	-	-	-	-	-	40	165	52	29	92	43	-	-	
	C (300)	-	-	-	-	-	-	-	-	-	39	132	52	-	-	
2800	D (350)	-	-	-	-	-	-	-	-	-	32	120	46	-	-	
	C (300)	-	-	-	-	-	-	-	-	-	42	158	55	-	-	
3000	D (350)	-	-	-	-	-	-	-	-	-	35	138	48	-	-	
	C (300)	-	-	-	-	-	-	-	-	-	46	190	58	-	-	
3200	D (350)	-	-	-	-	-	-	-	-	-	38	155	52	-	-	