

Economy Fixed Linear Bar Grilles

Description

For supply or extract, having a single set of fixed linear blades with 0° and 15° deflection options. Suitable for wall, cill or ceiling mounting.

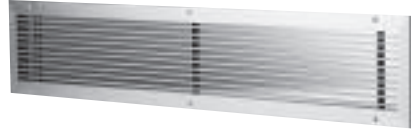

Construction

From extruded aluminium sections, frame 1.6mm thick blades either 4mm or 6mm thick. Hairline mitres mechanically held. Optional OBD is of extruded aluminium.

Size and Weight

Height from 50mm to 300mm in 25mm increments. Widths or lengths from 100mm to 3000mm in a single unit. Longer lengths can be supplied as multiple units.
 Grille only 11.5kg/m², Grille and OBD 19.5kg/m².
 Free area 4mm blades, approximately 70%.
 Free area 6mm blades, approximately 55%.

How to Specify

STATE QUANTITY, THE PRODUCT CODING AND THE SIZE WIDTH X HEIGHT

e.g. 10 Qty. S700V+1A 800 x 150.

Frame Style	Core	Options	Accessories
S 30mm Flange	70 0° Bars 4.0mm	0 Fixed Core	0 None
N 21mm Flange	71 15° Bars 4.0mm	C Removable Core	V Damper
0 Core Only	72 0° Bars 6.0mm		
	73 15° Bars 6.0mm		



Fixings	Finish
1 Flange Holes	A Satin Anodised
2 Neck Fixings	C PPC BS /RAL Colour
	D Mill Finish

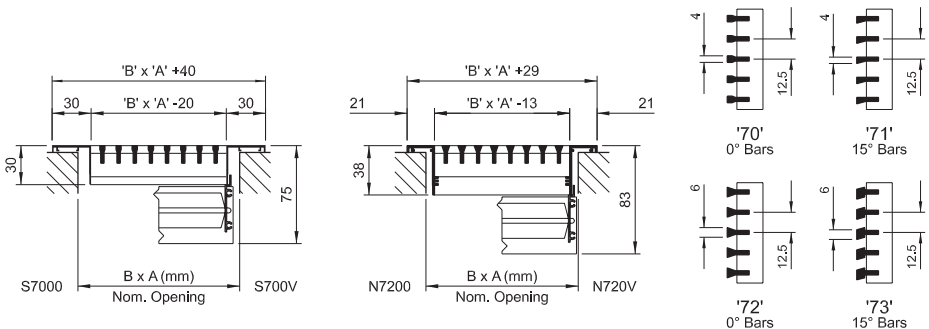
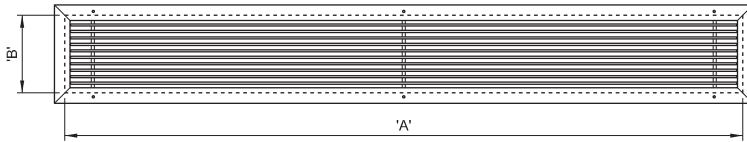

Technical Data Linear Bar Grilles

S7000
S7100
S3000
S3300
S7A00
S7B00

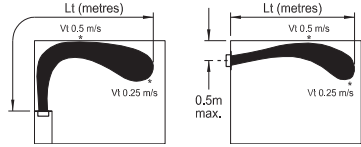
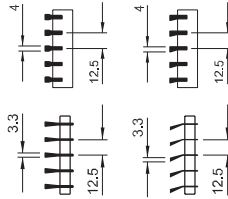

qm (l/s) (1000mm)	Nominal Duct H.	Psn (Pa) (Pascals)	Vf (m/s)	Lt (metres)	NC
40	50	2	1.25	0.9 - 1.8	-
50	50	3	1.50	1.5 - 3.0	-
60	50	6	2.00	2.3 - 4.1	-
75	50	9	2.50	2.7 - 5.0	18
	75	3	1.40	2.3 - 3.8	-
90	50	12	3.00	3.0 - 5.8	22
	75	4	1.65	2.4 - 4.3	-
	100	2	1.15	1.8 - 3.4	-
110	50	16	3.50	3.8 - 6.7	26
	75	6	2.00	3.0 - 5.3	14
	100	2	1.35	2.4 - 4.3	-
125	50	19	4.00	4.3 - 7.5	28
	75	8	2.25	3.0 - 5.7	15
	100	3	1.50	2.7 - 5.0	-
140	75	9	2.50	3.3 - 6.7	18
	100	5	1.75	2.7 - 5.4	-
	125	2	1.30	2.4 - 4.4	-
160	75	11	2.80	4.4 - 7.6	21
	100	6	1.90	3.3 - 6.0	15
	125	3	1.50	2.7 - 5.0	-
190	75	16	3.50	5.0 - 8.0	27
	100	8	2.40	4.0 - 6.4	19
	125	5	1.80	3.3 - 5.7	14
	150	3	1.50	3.0 - 5.0	-
230	75	22	4.20	6.0 - 10.0	33
	100	12	3.00	5.3 - 8.5	24
	125	7	2.20	4.7 - 7.0	17
	150	5	1.80	4.3 - 6.4	15
270	100	15	3.35	6.0 - 9.0	26
	125	9	2.50	5.6 - 8.0	20
	150	6	2.00	5.0 - 7.2	16
	200	3	1.50	4.3 - 6.0	-
310	100	17	3.80	7.3 - 10.6	29
	125	12	3.00	6.4 - 9.0	25
	150	8	2.35	5.3 - 8.2	20
	200	4	1.70	4.7 - 7.0	15
350	125	15	3.30	6.8 - 10.0	27
	150	10	2.65	5.7 - 9.0	22
	200	6	1.90	5.0 - 8.0	17
	250	3	1.50	3.7 - 6.8	-
390	125	17	3.65	7.5 - 11.0	29
	150	12	2.95	6.5 - 9.7	26
	200	6	2.10	6.0 - 9.0	18
	250	4	1.65	5.0 - 8.0	15
430	150	15	3.25	7.3 - 10.4	28
	200	8	2.35	6.8 - 9.7	21
	250	5	1.85	5.5 - 8.6	17
	300	3	1.50	5.0 - 7.7	14
470	150	16	3.50	8.0 - 11.0	30
	200	9	2.50	7.3 - 10.3	24
	250	6	2.00	6.0 - 9.3	19
	300	4	1.65	5.4 - 8.2	16
540	200	12	3.00	8.3 - 12.0	27
	250	8	2.30	7.5 - 11.0	22
	300	5	1.90	6.0 - 10.0	19

Grille Length (metres)	Multiply throw for sidewall and cill by the following factor	Adjust NC
0.9 - 1.5	1.00	0
1.6 - 2.5	1.10	+2
2.6 +	1.15	+5

Throw (Lt) and terminal velocity (Vt)

The throw distance given in the tables is the distance from the outlet to the opposing wall or half the distance between opposing discharge grilles. The short throw distance (Lt) given in the tables is that point at which the discharge velocity has been reduced to Vt 0.5Ms and the longer throws shown is the distance at which the discharge velocity has been reduced to Vt 0.25Ms.

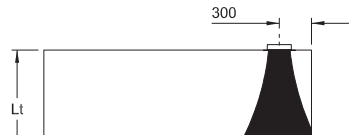
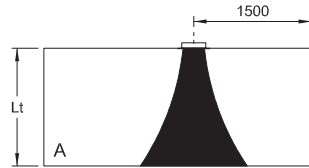

	-10° C (Td)	+/- 0 (Ti)	+10° C (Td)
A	Lt x 0.75	Lt x 0.60	Lt x 0.40
B	Lt x 1.0	Lt x 0.85	Lt x 0.60

Td = Temperature differential

Ti = Isothermal

Selection Example

- 1) Size a S330V+1C (15° blades on 12.5mm centres with a damper) mounted in a wall, 200mm from the ceiling, to supply 0.19m³/s giving a throw of 5 metres and less than NC 30. Grille to be 1200mm long.
- 2) Data in tables is per linear metre:
0.19m³/s / 1.2m (grille length) = 0.158 m³/s per metre.
- 3) Enter tables at nearest volume i.e. 0.16 and you will find that at 125 wide both throw and noise level are achieved.